



Swing Check Valves Type Bolted Cover
Class 600 DN 50-400 (2" – 16")
 Carbon, Alloy and Stainless Steel



Fig. VR600BC

Design:

BS 1868 & API 6D / ISO 14313
ASME B16.34

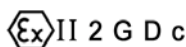



Swing Check Valves Class 600

Type Bolted Cover

Parts and materials

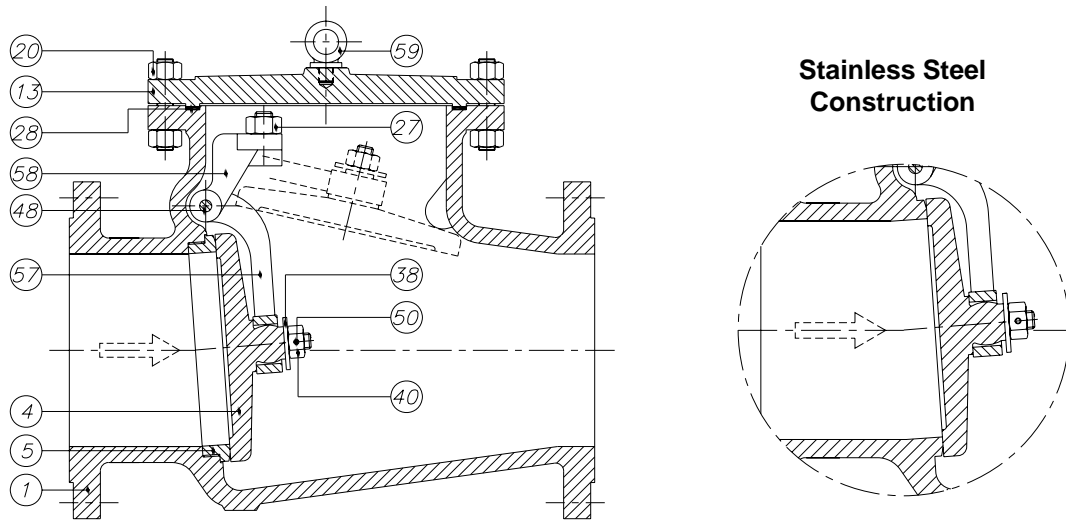

Trim Material

API 600 Trim No.	Stem / Backseat	Seating Surface Body / Wedge
1	13% Cr	13% Cr
2	SS 304	SS 304
3	SS310	SS310
4	13% Cr	13% Cr (Hard)
5 or 5A	13% Cr	HF
6	13% Cr	13% Cr / Cu Ni
7	13% Cr	13% Cr / 13% Cr (Hard)
8 or 8A	13% Cr	HF / 13% Cr
9	Monel	Monel
10	SS 316	SS 316
11 or 11A	Monel	HF / Monel
12 or 12A	SS 316	HF / SS 316
13	Alloy 20	Alloy 20
14 or 14A	Alloy 20	HF / Alloy 20

HF: Hard Facing using CoCr welding alloy (Stellite)

Item	Description	Material			
		Carbon Steel	Carbon Steel (Low Temp.)	Alloy Steel	Stainless Steel
1	Body	A 216 Gr.WCB	A 352 Gr.LCB	A 217 Gr.C5	A 351 Gr.CF8M
4	Disc	A105 + ER 410	A 182 Gr.F304	A 182 Gr.F6a	A 182 Gr.F316
5	Seat Ring	A105 + Stellite	A 182 Gr.F304	A 182 Gr.F6a + Stellite	-----
13	Cover	A 216 Gr.WCB / A 515 Gr.70	A 352 Gr.LCB / A 182 Gr.F304	A 217 Gr.C5	A 351 Gr.CF8M
20	Cover Bolt & Nut	A 193 Gr.B7 / A 194 Gr.2H	A320 Gr. L7 / A194 Gr. 7	A 193 Gr.B7 / A 194 Gr.2H	A 193 Gr.B7 / A 194 Gr.2H
27	Bracket Stud & Nut	A 193 Gr.B8 / A 194 Gr.8	A 193 Gr.B8 / A 194 Gr.8	A 193 Gr.B8 / A 194 Gr.8	A 193 Gr.B8M / A 194 Gr.8M
28	Gasket	SPW S.S. 304 / Graphited	SPW S.S. 304 / Graphited	SPW S.S. 304 / Graphited	SPW S.S. 316 / Graphited
38	Washer	AISI 410	AISI 304	AISI 410	AISI 316
40	Disc Nut	AISI 304	AISI 304	AISI 304	AISI 316
48	Hinge Pin *	A182 Gr.F6a	A182 Gr.F304	A182 Gr.F6a	A 182 Gr.F316
50	Split Pin	AISI 304	AISI 304	AISI 304	AISI 316
57	Hinge	A 216 Gr.WCB / A 515 Gr.70	A 352 Gr.LCB	A 217 Gr.C5	A 351 Gr.CF8M
58	Hinge Bracket	A 216 Gr.WCB / A 515 Gr.70	A 352 Gr.LCB	A 217 Gr.C5	A 351 Gr.CF8M
59	Lifting Hook	A105	A105	A105	A105

Item 5 only in Carbon Steel and Alloy Steel construction

* It's also manufactured with Hinge Pin passing through Body with Plug



Swing Check Valves Class 600

Type Bolted Cover

Dimensions

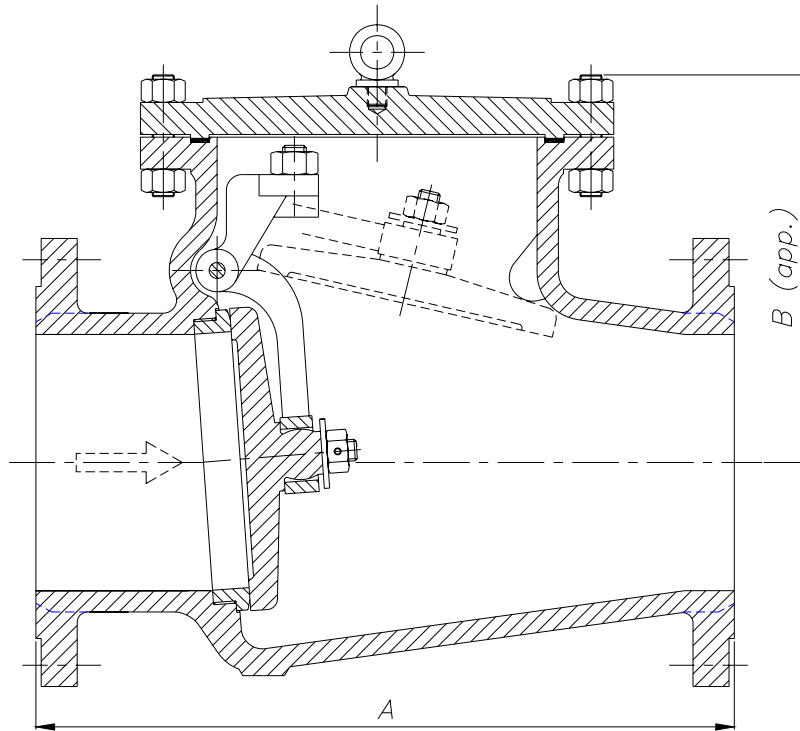

DN	A (RF/BW)	B	WEIGHT
50 (2")	292	160	29
65 (2½")	330	260	55
80 (3")	356	230	65
100 (4")	432	280	115
125 (5")	508	290	145
150 (6")	559	330	250
200 (8")	660	360	405
250 (10")	787	475	620
300 (12")	838	555	815
350 (14")	889	580	970
400 (16")	991	665	1215

(*) Dimensions in mm and weight in kg.



Swing Check Valves Class 600

Type Bolted Cover

General Characteristics, Cv, P&T Rating

GENERAL CHARACTERISTICS	Fig. VR600BC			
DESIGN STANDARDS				
Valves design	BS 1868 & API 6D	ASME B16.34		
End to End Dimensions	ASME B16.10 & ISO 5752			
Flanged Dimensions	ASME B16.5 & ISO 7005-1 Part. 1	ASME B16.47	BS 3293	MSS SP-44
Buttweld Dimensions	ASME B16.25			
Visual Inspection	MSS SP- 55			
Marking	MSS SP-25 & ISO 5209			
TESTS AND CERTIFICATES				
Pressure testing	API 598 & ISO 5208	BS 6755 Part. 1	MSS SP-61	
Other	ATEX, CE			

Cv Values in U.S. Gallons/min.

DN	Cv	DN	Cv
50 (2")	125	200 (8")	2200
65 (2½")	190	250 (10")	3300
80 (3")	280	300 (12")	4800
100 (4")	490	350 (14")	5850
125 (5")	800	400 (16")	8100
150 (6")	1150		

Pressure-Temperature (STANDARD CLASS According to ASME B16.34)

Temp °C	MATERIAL			
	A216 WCB Bar	A352 LCB Bar	A217 C5 Bar	A351 CF8M (**) Bar
-29 to 38	102,0	95,8	103,4	99,2
95	93,0	90,6	102,7	85,4
150	90,6	87,8	98,5	77,2
205	87,5	85,1	87,1	70,6
260	82,7	80,3	91,6	65,8
315	75,4	73,4	83,4	62,0
345	74,1	72,0	81,0	61,3
375	73,4		78,2	59,9
400	69,6		72,7	58,9
425	56,8		69,9	58,2
450	36,9		66,5	57,5
485	23,8		51,0	57,2
510	14,1		37,9	53,4
540	7,2		27,6	48,2
565			20,0 *	47,2 *
595			13,8 *	42,0 *
620			8,6 *	32,7 *
650			4,8 *	25,5 *
675				20,3 *
705				16,2 *
735				13,1 *
760				10,3 *
790				7,9 *
815				5,9 *

* FOR WELD END VALVES ONLY. FLANGE END RATINGS TERMINATE AT 540°C

** A351 CF8M at temperatures over 538°C (1000°F) to be used only if Carbon contents is 0,04% or higher.